

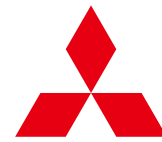

for a greener tomorrow



**MITSUBISHI
ELECTRIC**

Changes for the Better

FACTORY AUTOMATION

2-Dimensional Fiber Laser Processing Systems GX-F Series

GX-F



D-CUBES



GLOBAL IMPACT OF MITSUBISHI ELECTRIC



Through Mitsubishi Electric's vision, "Changes for the Better" are possible for a brighter future.

Changes for the Better

We bring together the best minds to create the best technologies. At Mitsubishi Electric, we understand that technology is the driving force of change in our lives. By bringing greater comfort to daily life, maximizing the efficiency of businesses and keeping things running across society, we integrate technology and innovation to bring changes for the better.

Mitsubishi Electric is involved in many areas including the following:

Energy and Electric Systems

A wide range of power and electrical products from generators to large-scale displays.

Electronic Devices

A wide portfolio of cutting-edge semiconductor devices for systems and products.

Home Appliance

Dependable consumer products like air conditioners and home entertainment systems.

Information and Communication Systems

Commercial and consumer-centric equipment, products and systems.

Industrial Automation Systems

Maximizing productivity and efficiency with cutting-edge automation technology.

Mitsubishi Electric continues challenge of being only FA supplier delivering highest satisfaction to our customers.

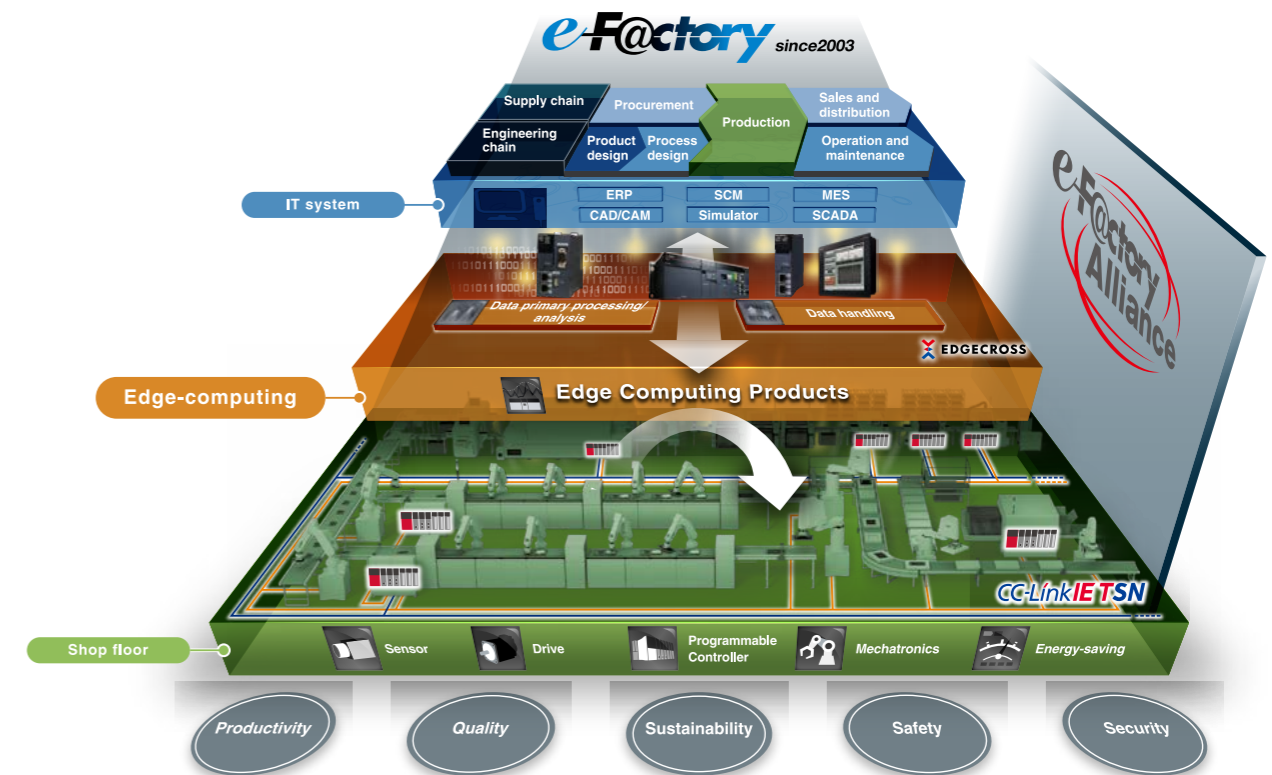

As the world's leading general electric device manufacturer, Mitsubishi Electric Corporation is engaged in a broad range of businesses from home electronics to space equipment. We are globally operating in the following five business domains: Energy and Electric Systems, Industrial Automation Systems, Information and Communication Systems, Electronic Devices and Home Appliances. For over ninety years since we started manufacturing the general-purpose motors, Mitsubishi Electric FA systems business sector has been supporting the manufacturing of not only Japan, China and other Asian countries but also the countries of the world. Through the years of our accumulation and advancement in

the FA and drive system controls, mechatronics and production technologies, we are expanding the diversity of our product lineup one after another ranging from the controllers, drive units and mechatronics products to power distribution control devices. In addition to such products and units of the factory automation, we are quick in providing solutions such as "e-F@ctory" and "iQ Platform" to innovate the manufacturing scene. From now on also, Mitsubishi Electric as the comprehensive FA supplier is delivering the products that meet our customer needs throughout the world.

INDEX

GX-F Overview	3	Options/Processing Capability	13
Continuous Processing & Reliability.....	5	Specifications/Layout	14
Fast Processing & Low Operating Cost	7	Laser Automatic Sorting System	15
Operability & Usability	9	Laser Automation System	17
Processing Performance	11	Overseas Support/Solutions.....	21

Introducing the highly reliable AI-powered "Non-stop Processing System" All-Mitsubishi Fiber Laser



Mitsubishi Fiber Laser Oscillator

New ----- P6

AGR-eco

New ----- P7

AGR-eco

AI Assistance

New ----- P5



An abbreviation of 'Mitsubishi Electric's AI creates the State-of-the-ART in technology'. Our AI technology brand, striving to make all devices more intelligent

Next Level Automation Solutions

Automatic Sorting System **New** --- P15 **LASERTING**
Automation System ----- P17

Processing head

High-Peak Piercing ----- P8
Zoom Head ----- P8

Nozzle Technology

AI Nozzle Monitor **New** ----- P5
Nozzle Changer **New** ----- P6

Newest Control Equipment

D-CUBES ----- P9
MEL'S AR ----- P10



Cutting-edge performance achieved with in-house production of key components



Mitsubishi Fiber Laser Oscillator

Control equipment

Processing head

Continuous Processing & Reliability



AI Assistance

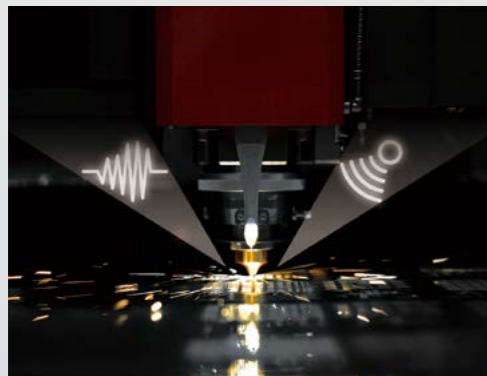

Quality of data measured during processing determined with AI

Feedback to processing conditions, etc.

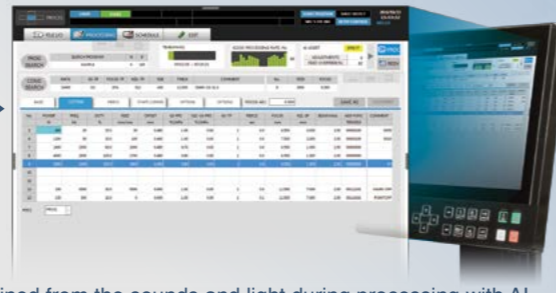

The processing state is determined from the sounds and light during processing with AI, using our AI technology "MaisartSM". In pursuit of a "non-stop processing system", with the world's first e-laser processing system built-in and functionality that automatically adjusts the laser processing conditions with AI.



* As of April 2019, internal research

AI Nozzle Monitor

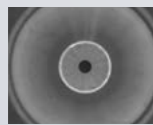

Nozzle OK
Automatically adjusts processing conditions

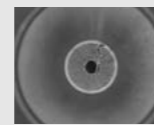

Nozzle NG
Automatically changes nozzle using nozzle changer



When nozzles are replaced with the nozzle changer, the nozzle condition is determined from images using AI. If the processing state is determined by the AI assistance, the nozzle condition is determined with AI using this function, and the nozzle is automatically replaced with the nozzle changer if necessary.



Nozzle Changer



Can be equipped with up to 21 nozzles*. Nozzles that are determined to be defective by the nozzle monitor are automatically replaced with new ones to support continuous processing for a long period of time. The ideal nozzle for processing can be selected from various types of nozzles, with more options than have conventionally been available.

* For 4kW and 6kW, 9 nozzles are equipped as standard and up to 21 nozzles can be optionally equipped
* For 8kW, 21 nozzles are equipped as standard

Mitsubishi Fiber Laser Oscillator **5** year warranty



Achieves both high reliability and high productivity with our new fiber laser oscillator built-in. Minimizes the risk of machine breakdowns.

Fast Processing & Low Operating Cost



High-Peak Piercing



The oscillator adapts to high-peak pulse conditions and optimally controls the beam and focus position, significantly reducing the piercing time. The piercing time for 25mm of mild steel has been reduced to 0.8 seconds, greatly improving the productivity for thick plates.

* For 8kW oscillator



Zoom Head



Conventional Head

3-step switching with lens selection (f5", f8", for mild steel thick plates)



Zoom Head

Stepless switching with zoom mechanism
Reduced setup time
Wider selection of processing conditions

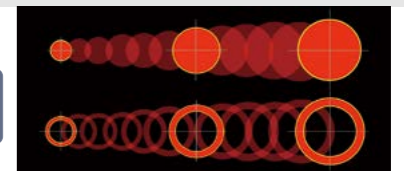

The "Zoom Head" processing head manufactured in-house utilizes Mitsubishi Electric's proprietary optical system technology and provides optimal control of the beam according to the material and plate thickness. Provides reliable processing for everything from thin to thick plates and supports stable production at the processing site.

Also, the range of selectable processing conditions has been expanded, making it unnecessary to exchange the processing lens according to the plate thickness and material, shortening the setup time.

AGR-eco(Advanced Gas Reduction)

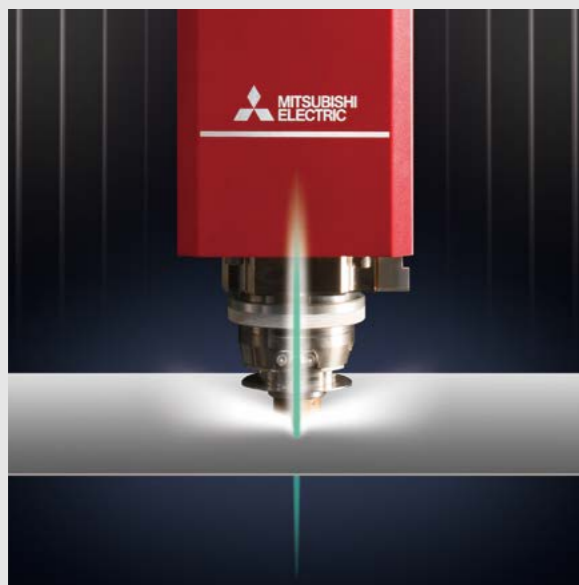

Our proprietary gas flow control reduces nitrogen gas consumption by up to 90%.¹ The processing speed and cutting surface quality have been improved for everything from thin to thick plates², providing unprecedented added value.

¹: Compared to our CO₂ laser
²: Applicable plate thickness <8kW>
Mild steel nitrogen cutting: t11mm to t9mm, stainless steel cutting: t11mm to t25mm

AGR-eco

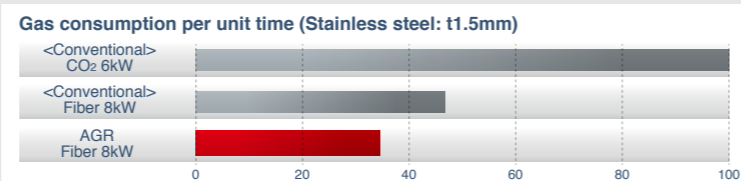
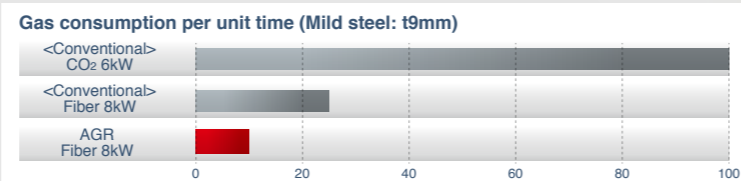

Mild steel (SS400) t9mm Nitrogen cutting



New Platform

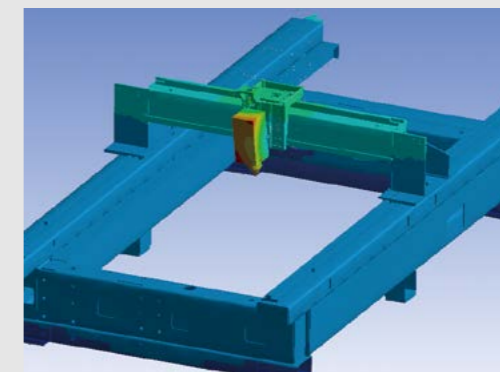

A dedicated platform developed to take full advantage of the features of the fiber laser. The new platform x all-Mitsubishi key parts achieve the fastest processing ever in Mitsubishi Electric's history, enabling both unprecedented productivity and precision.

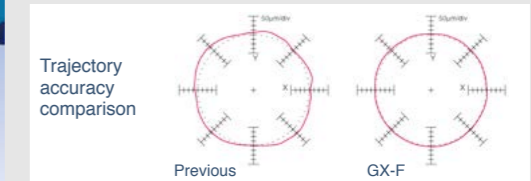

Operability & Usability



MEL'S AR

Without MEL'S AR

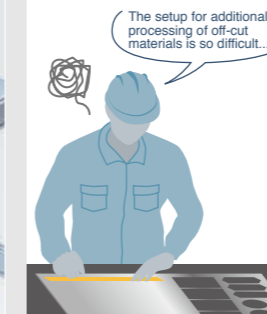

With MEL'S AR



Intuitive positioning with MEL'S AR*

MEL'S AR (Mitsubishi Electric's original AR technology) displays overhead images of the system at all positions without distortion, allowing the positional relationship between the material and processing head to be intuitively recognized. The program shape can be easily placed with a drag operation, significantly reducing the setup time for interrupt processing of off-cut materials.



Pre-conversion image from the camera in the processing system.

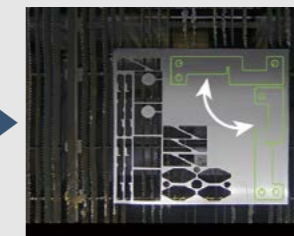

By superimposing the program shape on the converted image, positioning and workpiece placement for off-cut materials can be intuitively performed.



Press the start button to start processing.

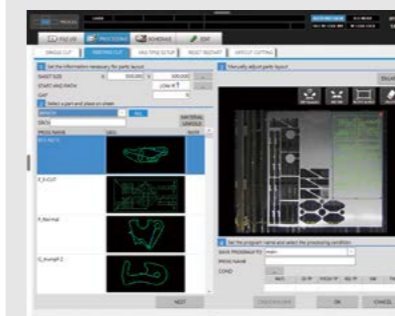

Simple Nesting

MEL'S AR enables simple, intuitive nesting of off-cut materials and supports the sudden addition of sheets to be processed.



Left-over Material Cutting Function

Specify an arbitrary point on the screen, and a route is generated. Then, press the start button to automatically cut the left-over material.

*Mitsubishi Electric's original AR technology (Augmented Reality) MEL'S AR is an optional product.

Newest Control Equipment D-CUBES



Intuitive operation similar to a smartphone with a large, 19-inch screen

Intuitive operation with multi-touch panel
Easily swipe to the required screen. Graphics can be easily scaled.

Customizable icons
Users can freely customize the icons on the screen. Delete unnecessary information and include only the necessary information.

Easily move the processing head with screen operations
Simply touch the destination on the screen and press the movement start switch to move the processing head to the specified position.



Visible Processing Progress

Check the elapsed processing time with control equipment, signal towers.

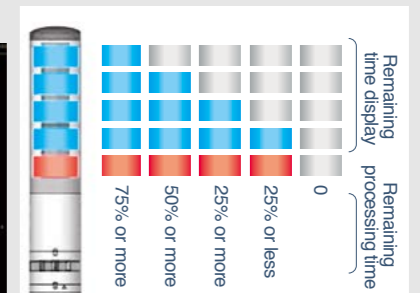

Processing Performance

Construction



Agricultural Machinery



Kitchen



Device



Plant



Mild steel thick plate

Oxygen

Material..... SS400
Thickness t25mm
Oscillator Output... 8kW

- Achieves a piercing time of 0.8 seconds with high-output oscillator. Significantly improves productivity.
- Zoom head automatically changes the beam diameter and beam mode, enabling high-quality processing.
- Achieves ϕ 3mm small-hole processing with an oscillator manufactured in-house and the optimal control technology.



Mild steel medium to thick plate

AGR-eco

Material..... SS400
Thickness t9mm
Oscillator Output... 8kW

- Fast processing of mild steel medium to thick plates with the high-output oscillator.
- Greatly reduces the cost with AGR-eco.
- With our proprietary gas flow control and zoom head, the beam diameter and beam mode are changed automatically, improving the cutting surface quality.

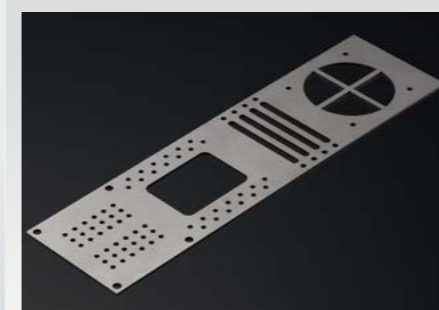

Stainless steel thin plate

AGR-eco

Material..... SUS304
Thickness t1mm
Oscillator Output... 4kW

- Non-stop fast processing of thin plates with F-CUT[®] technology.
- Greatly reduces the cost with AGR-eco.
- Fast and accurate processing with the new platform.

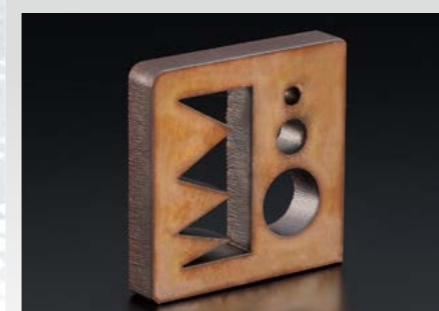

Pure copper thick plate

Air

Material..... C1100
Thickness t12mm
Oscillator Output... 8kW

- Processes highly reflective materials with anti-reflective technology.
- Anti-reflective material is not required, eliminating the post-processing.



Stainless steel thick plate

AGR-eco

Material..... SUS304
Thickness t25mm
Oscillator Output... 6kW

- Zoom head automatically changes the beam diameter and beam mode, enabling high-quality processing.
- Greatly reduces the cost by AGR-eco.



Options/Processing Capability

Main Functions/Options List

Model	
Zoom Head	Optimally controls the beam according to the material and thickness, supporting continuous processing
High-Peak Piercing	Shortens the piercing time when processing mild steel of 12mm or thicker
Magnetic Damage Reduction Function	Shortens recovery time in case of processing head collision
AI Assistance	Automatically adjusts the processing conditions if defects are found, supporting continuous processing
AI Nozzle Monitor	Checks the state of the nozzles and AI determines the quality, supporting continuous processing
Nozzle Changer (9 pcs.)	Replaces the nozzles automatically
Nozzle Changer (21 pcs.)	Reduces the setup time, supporting continuous processing
AGR-eco	Gas flow control reduces consumption of assist gas
MEL'S AR	AR technology enables intuitive positioning and reduces setup time
Fine Piercing	Reduces pulses that occur when piercing stainless steel or aluminum with nitrogen processing
FRG	Creates NC data with optimal path and supports fast processing of thin plates
Workpiece Lifter	Allows materials to be set more easily and reduces scratches on the backs
Workpiece Clamp	Secures the material and prevents warping of long materials
Additional window and LED	Additional window improves operability

Specifications/Layout

Specifications

Model	ML3015GX-F40	ML3015GX-F60	ML3015GX-F80
Drive system	Flying optic		
Control system	X,Y,Z simultaneous 3-axis control + Z-axis height sensing control		
Workpiece dimensions (mm)	3,050x1,525		
Pallet load weight (kg)	950		
Workpiece support height (mm)	890		
Stroke	X-axis (mm)	3,100	
	Y-axis (mm)	1,565	
	Z-axis (mm)	120	
Rapid feed rate	XY-axis (m/min)	Max. 170 (combined)	
Positioning accuracy	XY-axis (mm)	0.05/500	
	Z-axis (mm)	0.1/100	
Repeatability	XY-axis (mm)	±0.01	
Oscillator rated output (kW)	4	6	8
Power input (except peripheral equipment) (kVA)	23	30	36
Installation area (reference value) (mm)	13,000x5,200		
Weight (kg)	Processing system main body	Approx. 7,000	
	Pallet changer	Approx. 2,400	
	Cooling system	Approx. 800	

Processing Capability

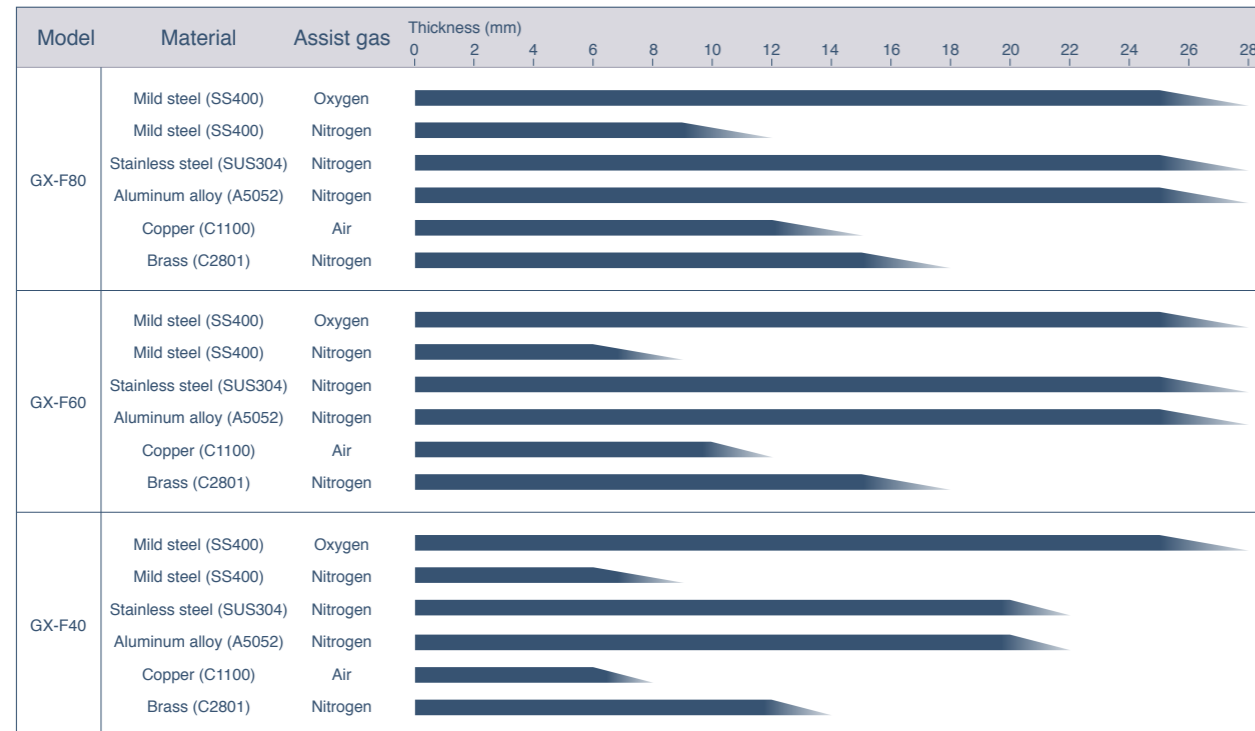

* The values listed in the above processing capability chart are the capabilities under specific conditions. The inspection conditions depend on the specifications.
 * Even if workpieces have the same standards, differences in processing performance and quality may occur depending on the surface condition and the composition.
 * Differences in processing performance and quality may occur depending on the processing shape.
 * For mild steel (SS400) with a plate thickness of 119mm or more, the values describe the capabilities when using steel plate LS (steel plate for laser cutting).
 * For the assist gas, gas equipment that meets the pressure/flow rate set according to the target model/gas type is required. For details, check the specifications.

Layout

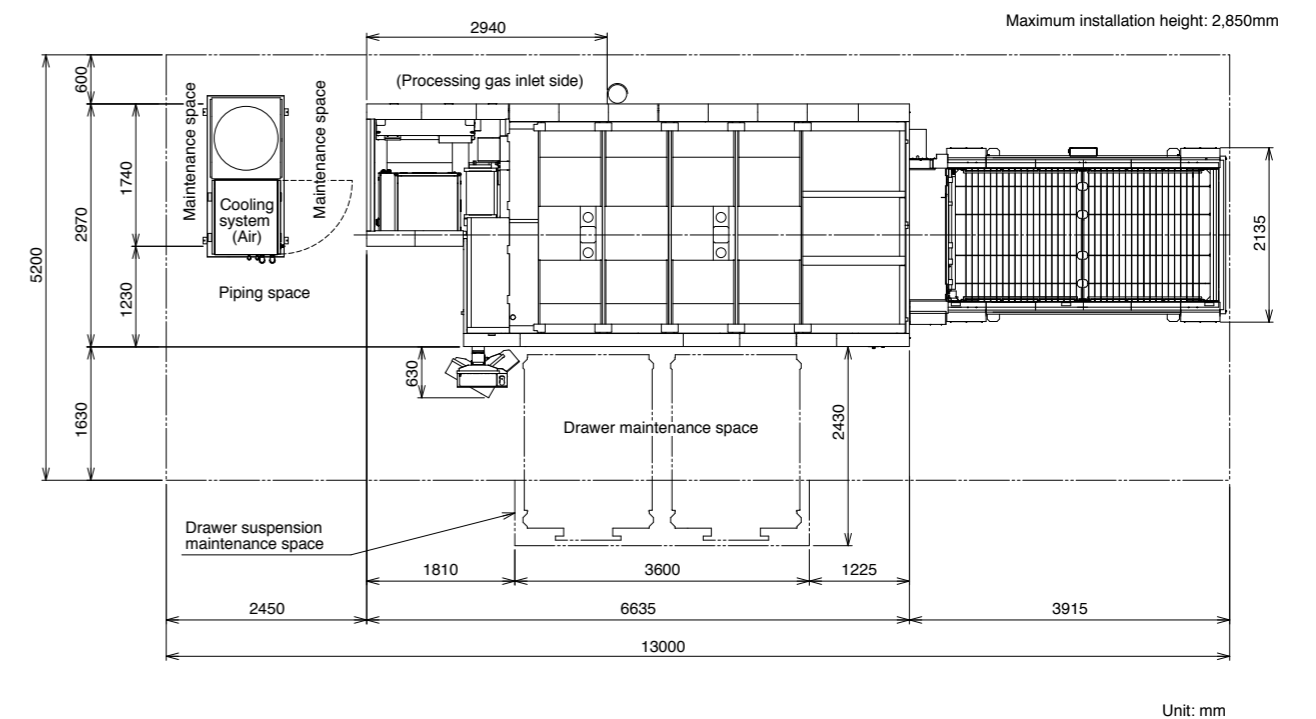

* Cooling method specification differs in the area. Please ask the sales company about layout drawing.

Laser Automatic Sorting System

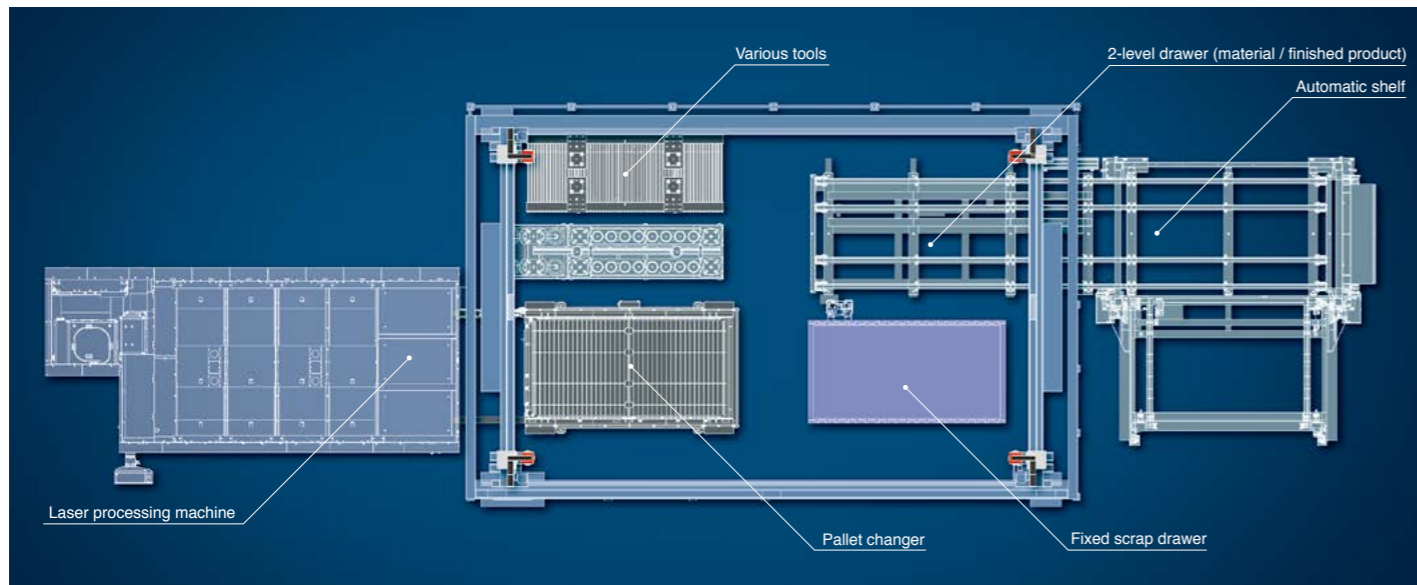

Complete automation of laser production process from material loading to sorting

Complete automation of production processes including material loading / laser processing / sorting / unloading off-cut materials / loading finished products.

Can be operated all day, greatly improving the productivity of the entire laser process.

Also contributes to a reduction in costs and human errors caused by manual work.

Mitsubishi Electric's entirely new take on automation in sheet metal processing.



Videos can be viewed.



Material Loading

Automatically loads materials from packaging materials. In addition to Mitsubishi's original 1-sheet pickup operation, a plate thickness detection sensor prevents the pickup of more than 1 sheet.



Sorting

Picks up finished products according to the shape. Eliminates the need for micro-joints and frees operators from time-consuming disassembly work.



Loading of Processed Products

Loads finished products that have been picked up onto pallets. A sorting destination pallet can be specified to enable a smooth transition to the next process.

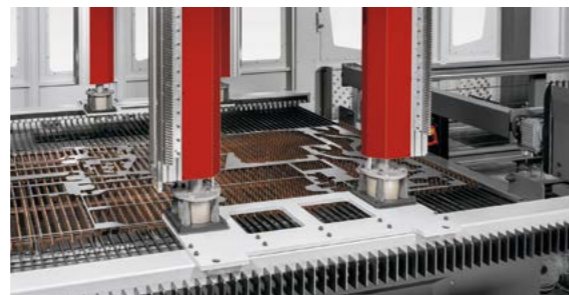

Unloading of Off-cut Materials

Replaces the arm tip with a forklift unit and transfers off-cut materials to the corresponding storage site. After unloading, small off-cut materials on the pallet are removed by the brush unit.

Broad adaptability with 4 independently controlled arms

4 independently controlled arms (patented) allow various processed products to be picked up regardless of shape. Enables sorting from 1mm to 25mm regardless of the plate thickness. * For ASTES4 SORT



Enables rotary loading and loading long products

The 4 arms move independently, allowing even long products to be picked up. Since it can rotate freely at the time of placement, processed products arranged alternately in the nesting will be loaded in the same orientation.

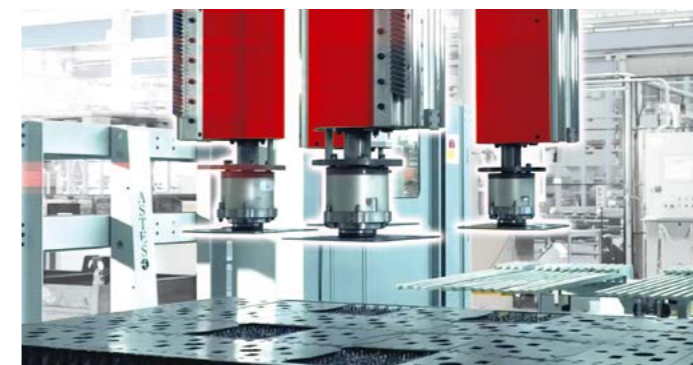

Enables simultaneous pickup of multiple parts

Can pick up a maximum of 4 products simultaneously, minimizing the takt time for sorting. Small finished products can be picked up collectively by attaching micro-joints and nesting them in one place.

Enables sorting of up to 25mm from thin to thick plates

Both mild steel and stainless steel of up to a thickness of 25mm can be sorted.

Equipped with intuitive sorting CAM as standard



Create sorting program with 4 clicks

Only 4 clicks are needed to achieve everything from reading component data to sending sorting programs. The operations can be easily learned by anyone.



Layout

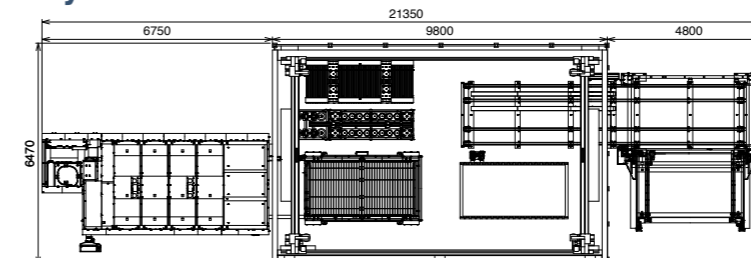

Specifications

Model	ASTES4SORT
Control system	4 arms Independent control
Sheet size	3000 x 1500mm
Material thickness	0.5~25mm
Total capacity	2000kg
Arm rotation	360°
Installation height	5350mm(Sorting unit)

Laser Automation System

Laser automation systems that improve productivity. Meets onsite needs. Automation achieves high productivity, minimum operator intervention and shorter delivery times. Supports micro-jointless processing and shortens post processing.

Pallet change type PCL Series

Continuous processing of thick plates
Micro-jointless processing
t25mm compatible

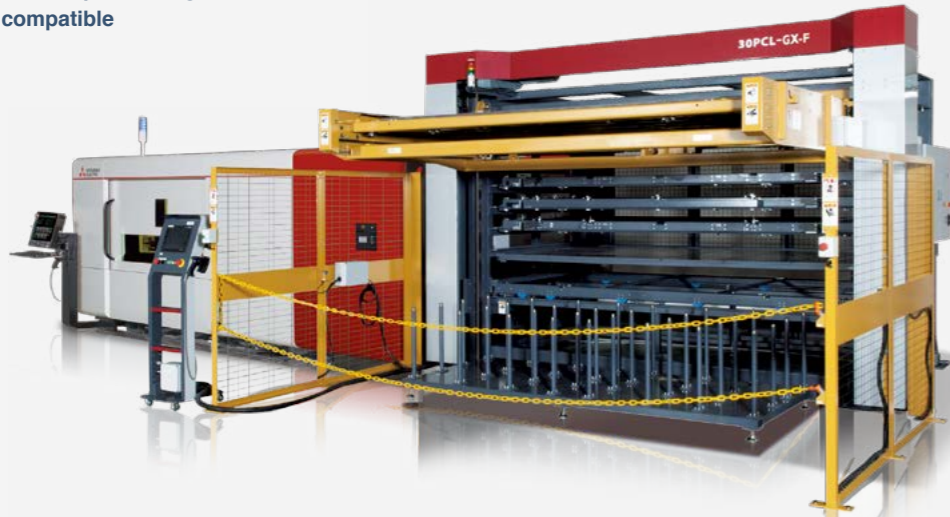

Videos can be viewed.

- Easy to operate, improves work efficiency and requires minimum intervention.
- Troubleshooting reduces downtime
- Small size simplifies locating installation space

Model	30PCL-GX-F[6]	30PCL-GX-F[10]	30PCL-GX-F[15]
Applicable laser processing machine	ML3015GX-F40/F60/F80		
Equipment height (mm)	2,920	3,840	5,030
Number of pallets	6	10	15
Material setting position (mm)	715mm above the floor (Free bearing height)		
Fixed table with free bearings	Standard equipment (fixed position)		
Material clamp position	Standard: 2 locations on Y-axis of each pallet (manual)		
Workpiece support intervals	Standard: 75mm (Options: 25/50mm)		

Layout

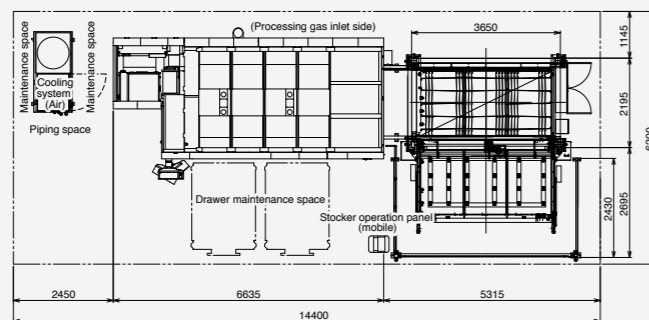

(Ex.) 30PCL-GX-F

Flexible loader & unloader MA Series

Processing of 2t packaging materials
Continuous processing of 2t packaging material is also possible by combining shelves for materials and finished products
Flexibly supports placement and number of carts, enables retrofit and expansion

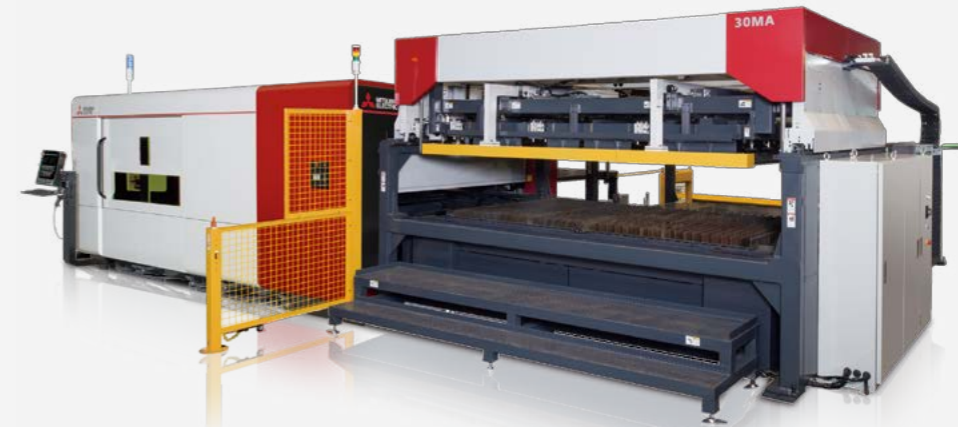

Videos can be viewed.

- Enables interrupt operation
- Directly loading to the processing pallet with a crane, forklift, etc. is possible

Model	30MA	
Target workpiece	Material	Mild steel plate, stainless steel plate
	Thickness	t1 to t12mm (Loadable sheet thickness)
	Dimensions	914mmx1,829mm(3'x6') 1,000mmx2,000mm 1,220mmx2,440mm(4'x8') 1,525mmx3,050mm(5'x10')
Transport unit	Weight	450kg
	Load	Suction unit
Material cart	Unload	Forklift unit (specification combined with suction unit)
	Amount	1 unit
	Specifications	Rail-conveyed type material cart (Lower level of 2 level cart)
Finished product cart	Maximum loadable height (mm)	300mm (Including 100mm thick wood platform)
	Maximum loadable weight (kg)	3,000kg
	Amount	1 unit
Automatic operation	Specifications	Rail-conveyed type finished product cart (Upper level of 2 level cart)
	Maximum loadable height (mm)	300mm (Including 100mm thick wood platform)
	Maximum loadable weight (kg)	3,000kg
Equipment height (mm)	Next workpiece preparation time	160 seconds or less
	Pallet change time	Approx. 40 seconds (Note: Check the processing system specifications)
		2,480mm

Layout

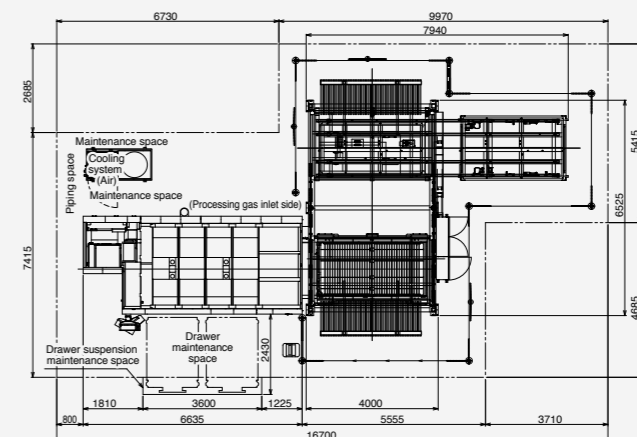

A series of horizontal dashed lines for writing on page 19.

A series of horizontal dashed lines for writing on page 20.

Overseas Support

Service bases are established around the world to provide customer support.



Americas

AMERICA
MC Machinery Systems, Inc.
 85 Northwest Point Blvd Elk Grove Village, IL 60007, U.S.A.
 Languages: English/Japanese
 Product: EDM Laser
 TEL (sales): 1-630-616-5920 FAX (sales): 1-630-860-4068
 TEL (service): 1-630-616-2970 FAX (service): 1-630-860-9816
 TEL: 1-630-616-5900 FAX: 1-630-860-7824
 TEL: 1-630-616-2965 FAX: 1-630-860-7824
 HP: <http://www.mcmachinery.com/>

MEXICO
MC Machinery Systems de Mexico S.A. de C.V.
 Lateral Carretera Estatal 431 km 2+200, Lote 62 Nave #1 Parque Tecnológico Innovación Querétaro C.P. 76246E1 Marqués, Querétaro, México
 Languages: English/Spanish/Japanese
 Product: EDM Laser
 TEL: 52(442)221-6159 FAX: 52(442)221-6170
 HP: <http://www.mcmachinery.mx/>

Asia

KOREA
MITSUBISHI ELECTRIC AUTOMATION KOREA CO.,LTD.
 1480-6, Gayang-dong, Gangseo-gu, Seoul 157-200, Korea
 Languages: Korean/Japanese
 Product: EDM Laser Laser-Drilling
 TEL: 82-2-3660-9574 FAX: 82-2-3663-0475
 HP: <http://www.mitsubishi-automation.co.kr/>

TAIWAN
SHIN WU MACHINERY TRADING CO.,LTD.
 No.122, WU-KUNG 2ND, ROAD, WU KU DIST., NEW TAIPEI CITY, TAIWAN, R.O.C.
 Languages: Chinese/English
 Product: EDM Laser Laser-Drilling
 TEL: 886-2-2299-2355 FAX: 886-2-2299-0288
 HP: <http://www.shinwu.com.tw/>

SINGAPORE
MITSUBISHI ELECTRIC ASIA PTE, LTD.
 307 Alexandra Road, Mitsubishi Electric Building, Singapore 159943
 Languages: Chinese/English
 Product: EDM Laser Laser-Drilling
 TEL: 65-6473-2308 FAX: 65-6476-7439
 HP: <http://www.mitsubishielectric.com.sg/>

INDONESIA
PT. MITSUBISHI ELECTRIC INDONESIA
 Gedung Jaya 8th Floor, J.L. MH. Thamrin No.12, Jakarta Pusat 10340, Indonesia
 Languages: Indonesian/English
 Product: EDM Laser
 TEL: 62-21-3192-6461 FAX: 62-213-1923-942

Asia

THAILAND
MITSUBISHI ELECTRIC AUTOMATION (THAILAND) CO.,LTD.
 Bang-Chan Industrial Estate No.111 Soi Serithai 54, T.Kannayao, A. Kannayao, Bangkok 10230, Thailand
 Languages: Thai/English/Japanese
 Product: EDM Laser Laser-Drilling
 TEL: 66-2-517-1326 FAX: 66-2-919-8717
 HP: <http://www.meath-co.com/>

VIETNAM
MITSUBISHI ELECTRIC VIETNAM CO.,LTD.
HOCHIMINH CITY HEAD OFFICE
 Unit 01-04, 10th Floor, Vincom Center, 72 Le Thanh Ton Street, District 1, Ho Chi Minh City, Vietnam
 Languages: Vietnamese/English/Japanese
 Product: EDM Laser
 TEL: 84-8-3910-5945 FAX: 84-8-3910-5947
 HP: <https://www.mitsubishielectric.com/vn/index.html>

HANOI BRANCH
 6th Floor Detch Tower
 8 Ton That Thuyet Street, My Dinh 2 Ward, Nam Tu Liem District, Hanoi City, Vietnam
 Languages: Vietnamese/English/Japanese
 Product: Laser Laser-Drilling
 TEL: 84-4-3937-8075 FAX: 84-4-3937-8076
 HP: <https://www.mitsubishielectric.com/vn/index.html>

China

CHINA
MITSUBISHI ELECTRIC AUTOMATION (CHINA) LTD.
 No.1386 Hongqiao Road, Mitsubishi Electric Automation Center, Shanghai, China
 Languages: Chinese/Japanese
 Product: EDM Laser Laser-Drilling
 TEL: 86-21-2322-3030 FAX: 86-21-2322-3000
 HP: <http://www.meach.cn>

Europe

GERMANY
MITSUBISHI ELECTRIC EUROPE B.V. - German Branch
 Mitsubishi-Electric-Platz 1, 40882 Ratingen, Germany
 Languages: German/English
 Product: EDM Laser Laser-Drilling
 TEL: 49-2102-486-0 FAX: 49-2102-486-1120
 TEL: 49-1801-486-600(Free Dial)
 HP: <http://www.mitsubishi-laser.de/>
 Supported in all of Europe, the Middle East, and Africa. Please inquire for details.

India

INDIA
MC Craftsman Machinery Pvt. Ltd.
 124, Sangothipalayam Road, Arasur Post, Coimbatore - 641 407 India
 Languages: English
 Product: EDM Laser
 TEL: 91-422-3226367 FAX: 91-422-3226367
 HP: <http://www.mccm.in/>

Supported models vary by region. Please inquire at each branch office.
 Notes: Please contact a Japanese branch office in advance if you wish to use an overseas local service for indirect export.
 This content may change depending on the situation.

EDM Electrical Discharge Machines
 Laser Laser Processing Machines
 Laser-Drilling Laser Drilling Machines

Engineers answer technical questions covering everything from machining to training and after-sale service.



Application

Application engineers are available to help optimize your machining processes through technical consultations via telephone, e-mail or fax.



Show room

Industrial mechatronics products of Mitsubishi Electric such as laser processors and EDMs are exhibited. Veteran engineers welcome visitors and explain the benefits of our products.



After-sales service

We provide after-sales service for machine repair and adjustment by an experienced staff, including OEM replacement and accessory parts.



Training

We provide laser trainings from basic operation to advanced programming and setup in support of all levels of laser operators.

YOUR SOLUTION PARTNER

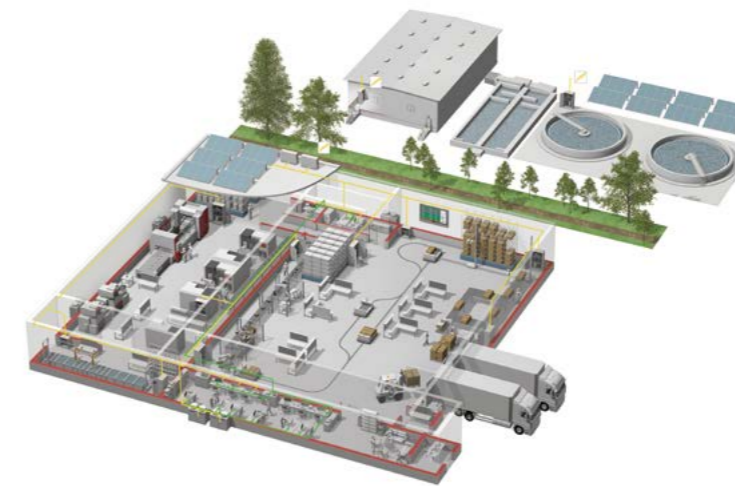

Mitsubishi Electric offers a wide range of automation equipment from PLCs and HMIs to CNC and EDM machines.

A NAME TO TRUST

Since its beginnings in 1870, some 45 companies use the Mitsubishi name, covering a spectrum of finance, commerce and industry.

The Mitsubishi brand name is recognized around the world as a symbol of premium quality.

Mitsubishi Electric Corporation is active in space development, transportation, semi-conductors, energy systems, communications and information processing, audio visual equipment and home electronics, building and energy management and automation systems, and has 237 factories and laboratories worldwide in over 121 countries.

This is why you can rely on Mitsubishi Electric automation solution - because we know first hand about the need for reliable, efficient, easy-to-use automation and control in our own factories.

As one of the world's leading companies with a global turnover of over 4 trillion Yen (over \$40 billion), employing over 100,000 people, Mitsubishi Electric has the resource and the commitment to deliver the ultimate in service and support as well as the best products.



Low voltage: MCCB, MCB, ACB



Medium voltage: VCB, VCC



Power monitoring, energy management



Compact and Modular Controllers



Inverters, Servos and Motors



Visualisation: HMIs



Numerical Control (NC)



Robots: SCARA, Articulated arm



Processing machines: EDM, Lasers, IDS



Transformers, Air conditioning, Photovoltaic systems

* Not all products are available in all countries.



[YouTube] [YouTube logo] is a trademark or registered trademark of Google Inc.

MITSUBISHI ELECTRIC CORPORATION

HEAD OFFICE: TOKYO BLDG., 2-7-3, MARUNOUCHI, CHIYODA-KU, TOKYO 100-8310, JAPAN
NAGOYA WORKS: 1-14, YADA-MINAMI, 5-CHOME, HIGASHI-KU, NAGOYA 461-8670, JAPAN

- * Not all the models are supported in all the countries and regions.
- * The machine specifications differ according to the countries and regions. Please check with your dealer.
- * The processing data provided in this brochure is for reference only.